



### OPTIONS



### VERSIONS

Type	Current per Winding A	Holding Torque Ncm	Resistance per Winding Ohm	Inductance per Winding mH	Rotor Inertia gcm <sup>2</sup>	Weight kg	Length „A“ mm
ST2018S0604	0.6	1.8	6.5	1.7	2	0.06	33
ST2018M0804	0.8	3	5.4	1.5	3.6	0.08	42
ST2018L0804	0.8	3.6	6	2.2	4.3	0.09	48

### ORDER IDENTIFIER

**ST2018S0604-**  
A = single shaft  
B = double shaft

### ACCESSORIES

**ZK-JST-VL-4** Cable for XHP4 Plug

### DIMENSIONS (IN MM)

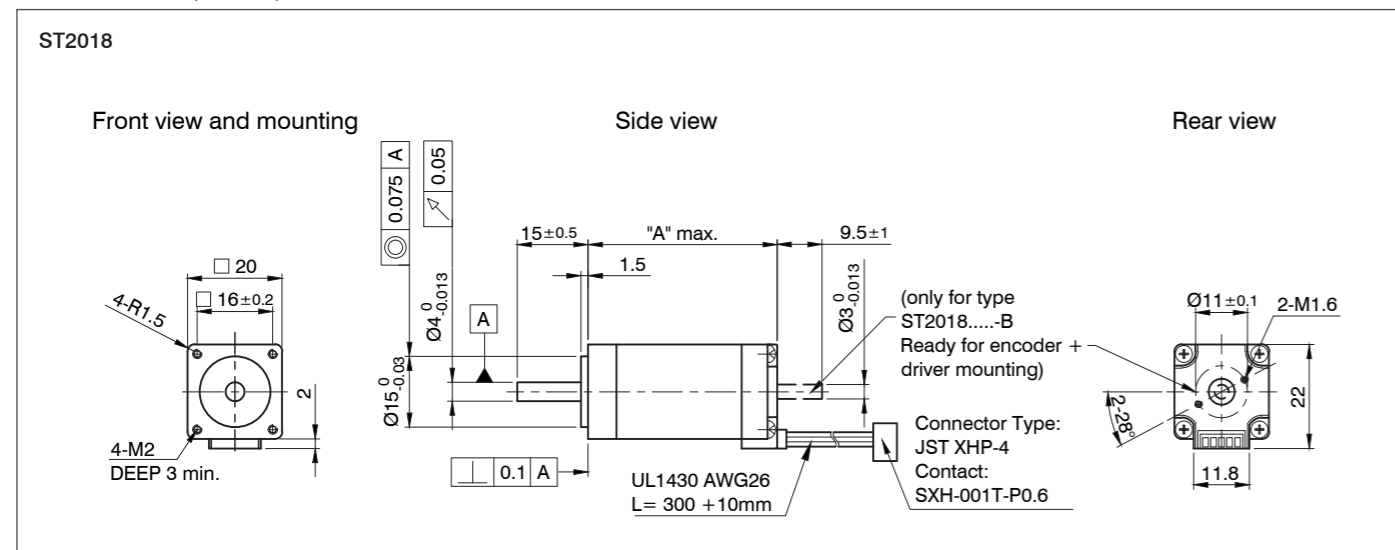

### TORQUE CURVES

